

WINEGARD®

Movin' View™

Automatic Digital Satellite Mobile Antenna Model MV-0500

Made in the U.S.A.

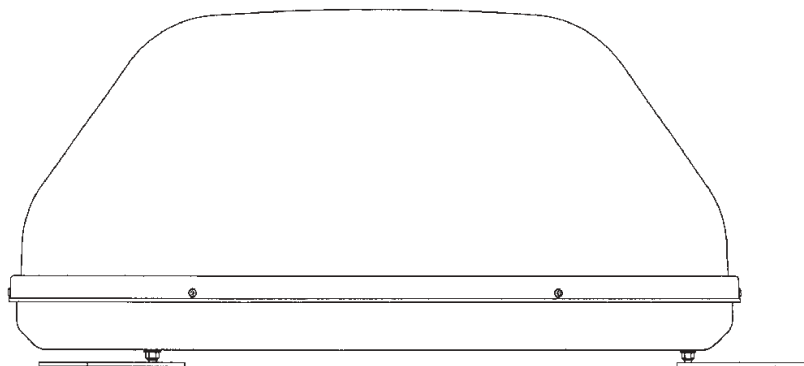
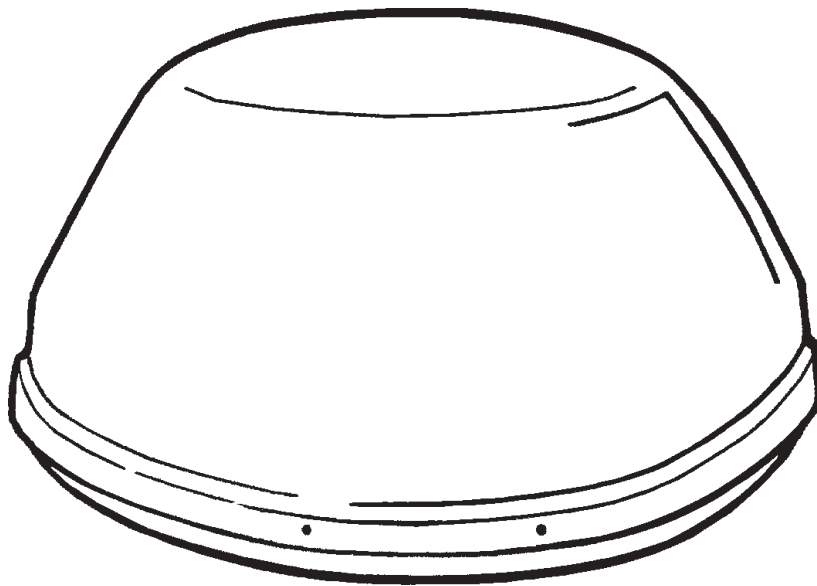

Winegard Company • 3000 Kirkwood St. • Burlington, IA 52601-2000
319/754-0600 • FAX 319/754-0787 • www.winegard.com
Printed in U.S.A. © Winegard Company 2002 2451018

Introduction/How Does Digital Satellite TV Work?

Introduction

Congratulations! You have purchased one of Winegard's latest developments in the mobile satellite reception product line —the Movin' View™. This system, used with your digital satellite receiver, will deliver the best reception possible using GPS (Global Positioning System) and precision gyroscopes.

How Does Digital Satellite TV Work?

Satellite programming originates from an “uplink” facility on Earth — the facility receives many signals from different sources, combines the signals digitally and transmits to the satellites. The satellites (22,300 miles above Earth) receive the uplink signal, amplify it and then transmit it back to earth in the Ku frequency band. This signal is concentrated and reflected to the LNBF* located at the “focal point” of the dish. The LNBF amplifies and converts the signal to the 950 to 2050 MHz range. The signal is then passed through a coaxial cable to the receiver where individual channel selection and processing take place.

* Low Noise Block Converter Feed

For Programming information call:
DISH NETWORK™ - 1-800-333-DISH (1-800-333-3474)
DIRECTV® - 1-800-DIRECTV (1-800-347-3288)
ExpressVu™ 1-888-SKY-DISH (1-888-759-3474)

Your new Winegard RV Digital Satellite System is an easy-to-use satellite TV reception system. Because it mounts on the top of your recreational vehicle, it goes where you go and provides quality reception of digital satellite signal in the continental United States only.

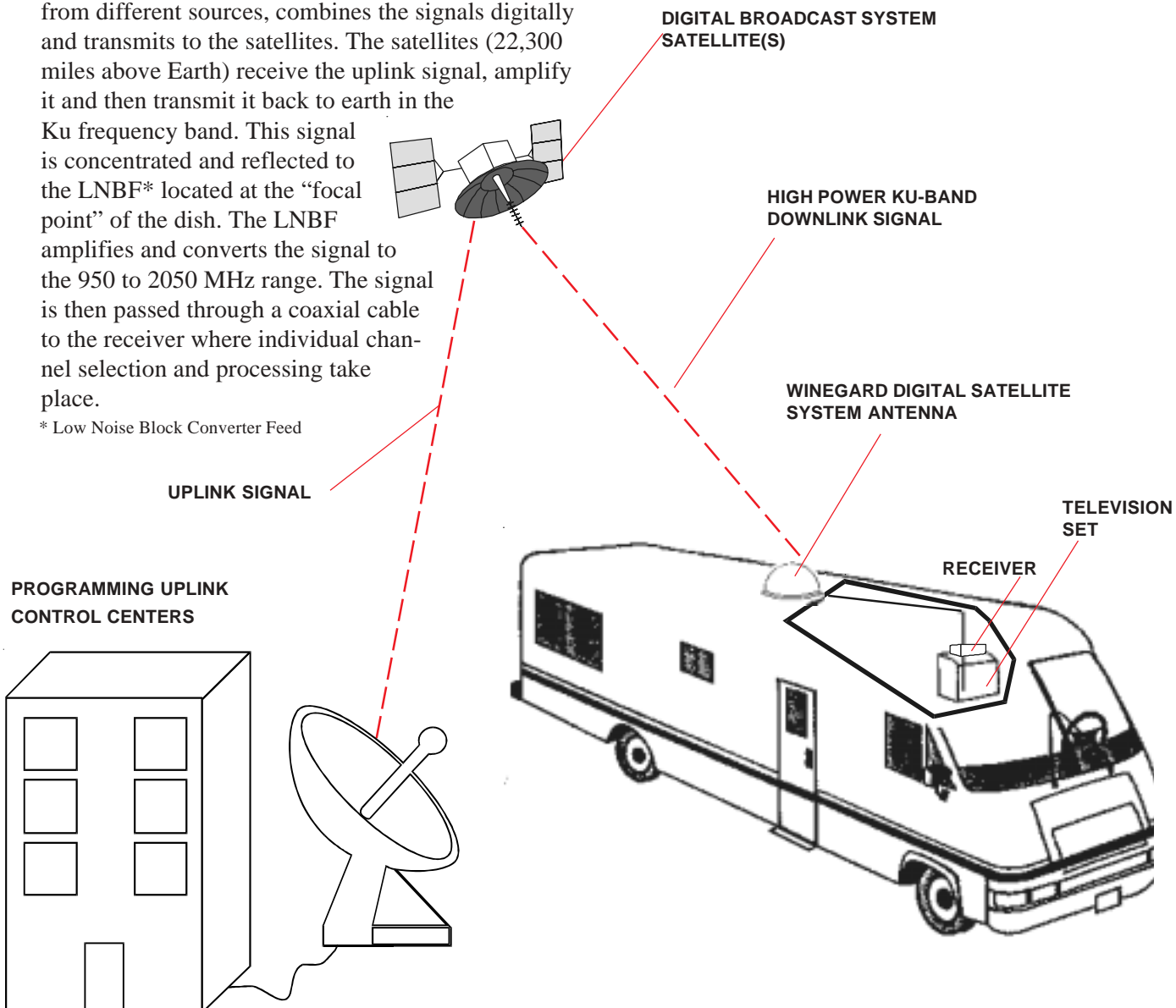

Parts Included • Tools Needed • How to Unpack

About this manual —

We hope this manual will provide clear instructions to install and operate the MV-0500.

Two symbols have been used —



Indicates caution should be taken!



Indicates suggestions to make processes easier for you.

PARTS INCLUDED:

- | | |
|-------------------------------|--|
| 1 Radome | 1 Cable entry plate |
| 3 base mounting feet | 1 large yellow spade connector |
| 1 Power switch | 2 small red spade connectors |
| 2 Wall plates (white & brown) | All required screws and washers |
| 1 Surface mount bracket | 1 base with electronics, dish, dual LNBF |
| 2 Cable clamps | 1 tube silicone |

TOOLS NEEDED FOR UNPACKING & INSTALLATION:

- | | |
|--|--|
| 7/16" open end wrench | 1/2" Open end wrench |
| Level | Crimping tool for coax connections |
| Drill w/3/4" bit | Crimping tool for electrical connections |
| 1-1/4" hole saw (if mounting switch in wall) | Small blade screw driver |
| 5/16" Socket for roof screws | Pliers |
| 1/8" Allen wrench | Sealant (consult RV manufacturer for proper type for your roof material) |

UNPACKING THE UNIT

1. Open box and remove packing material.



If using knife to open carton, **BE CAREFUL.** Do not cut the dome on the unit.

2. Lift unit out of box vertically. **Do not turn box and "roll" out, or turn upside down to remove.**



USE 2 PEOPLE when removing the unit from the carton.

LIFT UNIT STRAIGHT UP

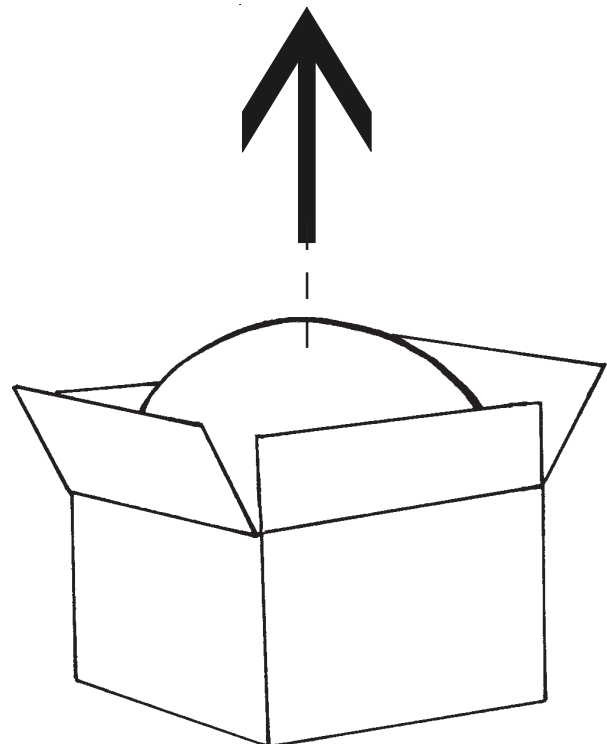

Installation Diagram

FIGURE 1

FRONT OF VEHICLE

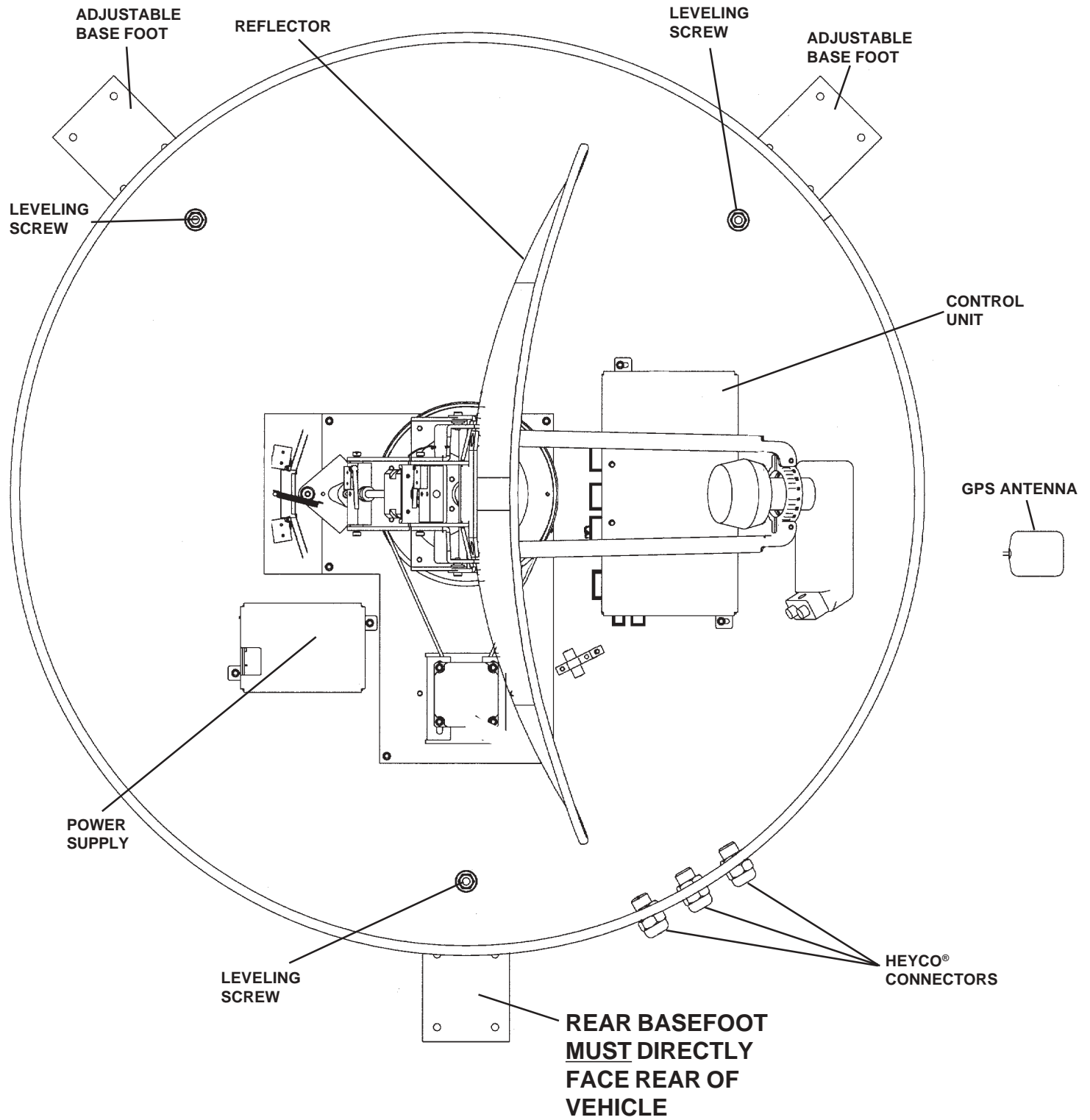

BACK OF
VEHICLE

Installing unit on roof of vehicle —



Install in DRY conditions only!

IMPORTANT! Do not install this system in the rain, or under any wet conditions. Moisture may affect electronics and void your warranty!

- For best performance and to reduce signal acquisition time, park vehicle on a level surface.
- Select a level spot on your roof for installation.
 - The unit should be no more than $\pm 1^\circ$ off level.
 - Be sure no roof-mounted equipment is blocking the satellite “line of sight.”
 - You will need to decide where the wires will enter the vehicle. A coax and an 18 gauge power wire will need to be placed in the vehicle. The power wire will go to the nearest +12 VDC power source; the coax will be routed through the demultiplexer to your satellite receiver. These wires should be hidden.
- Remove screws holding dome to base and remove dome. Place dome in safe spot to avoid damage. Place base on vehicle roof in the location selected.
- Remove wire ties used for shipping. There are three; one on each side of the reflector and one at the rear of the reflector holding down the counterweight. See Figure 1, page 4.
- Determine which programming you will be using. This will determine how you set your switches.

For **DISH Network™** set switches to **119°**.

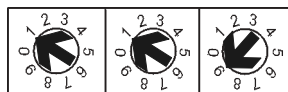

For **DIRECTV®** set switches to **101°**.

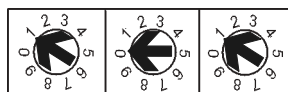

For **ExpressVu™** set switches to **092°**.

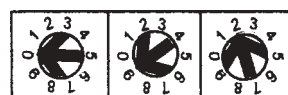

If you have trouble seeing the numbers, try using a magnifying glass!

- On each foot, screw the flange nut to the base of the leveling screw on the mounting foot, flange up. Place rubber washer, with the rubber side up, on the nut, Figure 2. Push mounting foot under base. Push foot screw through the base and tighten lock nut to secure foot to base. Be sure the base feet are pointing away from the base. Base feet will be removed later during install.

FIGURE 2

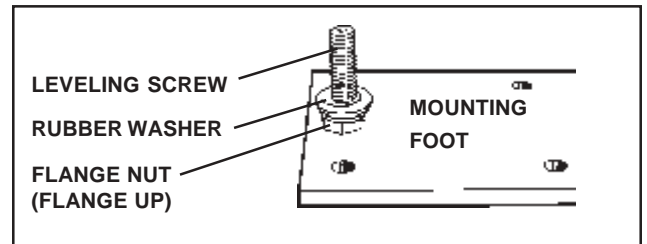

- After selecting location for unit (see step 2), put the unit on the centerline of the coach.

REAR MOUNTING FOOT MUST FACE DIRECTLY OFF REAR OF VEHICLE,

Figure 1. There is a 30 foot power cord and 30 foot coax cable going through the Heyco® connectors on the base.

Placing the rear base bracket on the centerline, facing the rear of the vehicle, will center the unit.

- Using the chart, determine the **minimum** distances to other equipment. Measure these distances as demonstrated in Figure 3.

Obstruction Ht.	Unit Clearance
8"	4"
10"	11.5"
12"	19"
15"	32"

FIGURE 3

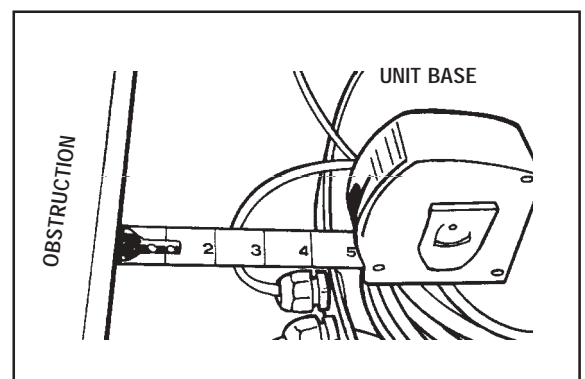

Installation

ROOF INSTALLATION, continued

9. Place the unit on the roof in its permanent location and mark around the base bracket, Figure 4. (Make sure the **rear adjustable base foot is directly facing the back of the coach.**)

FIGURE 4

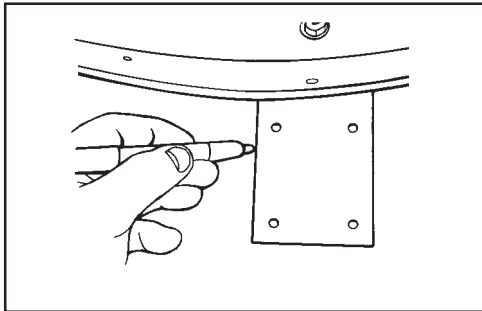

10. Clean roof area where the base feet will be attached to the roof. Do not erase your marks!

11. Put approved sealant in the area under the base feet. Place base foot on top of the sealant and screw down using (2) #10 screws (provided) for each base foot.

12. Unscrew the locknuts in the base and remove the base from feet. Put the other (4) #10 screws into the roof through the remaining holes in the base feet.

13. After all base brackets are secured to roof, put sealant on top of foot and screws. Place base on leveling screws located on base feet and install nut and rubber washer on leveling screw.

FIGURE 5

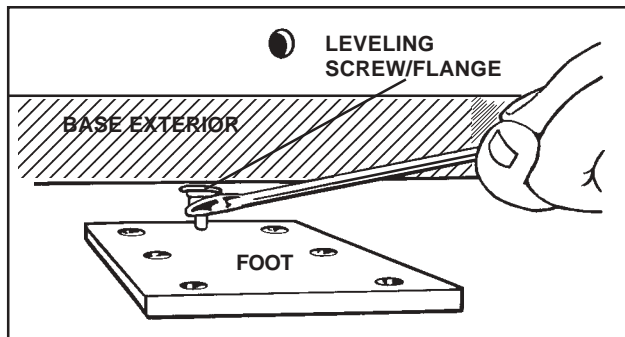

14. Leveling the base is done by tightening or loosening the flange nut under the base, Figure 5.

Use an electronic level to adjust base so there is **no more than +/- 1°** off level in all directions. Place level on base of unit if possible. (If your level will not fit inside the base plate, place on outside edge.) Level front to back and side to side. Raise and lower by adjusting flange nut under base. After leveling base, secure inside base with rubber washer, rubber side down toward base, and lock nut.

GPS installation —

The GPS antenna is pre-wired and has a 3 foot cable running through one of the Heyco® connectors.

When deciding where to place GPS antenna, DO NOT SECURE! After wiring the receiver and initializing your system, you will need to test the system (“Initializing and replacing dome” on page 8).

Determine location for GPS antenna. It is recommended you place the GPS antenna between unit base and side edge of vehicle, 90° from rear mounting bracket, Figure 6.

The recommended location for the GPS antenna is based on having a level location and a clear view of the sky. If another location, further from the base, is desired, loosen the Heyco connector and pull out additional wire in the base. **You must re-wrap and re-tie the GPS cable inside the dome** to prevent interference with the LNBF. **Failure to do so will result in malfunction!** Tighten Heyco connectors when done.

IMPORTANT! The GPS must be located away from obstructions on roof of vehicle and other obstructions such as trees, tall buildings, etc. **You must have a clear view of the sky for proper operation.**

FIGURE 6

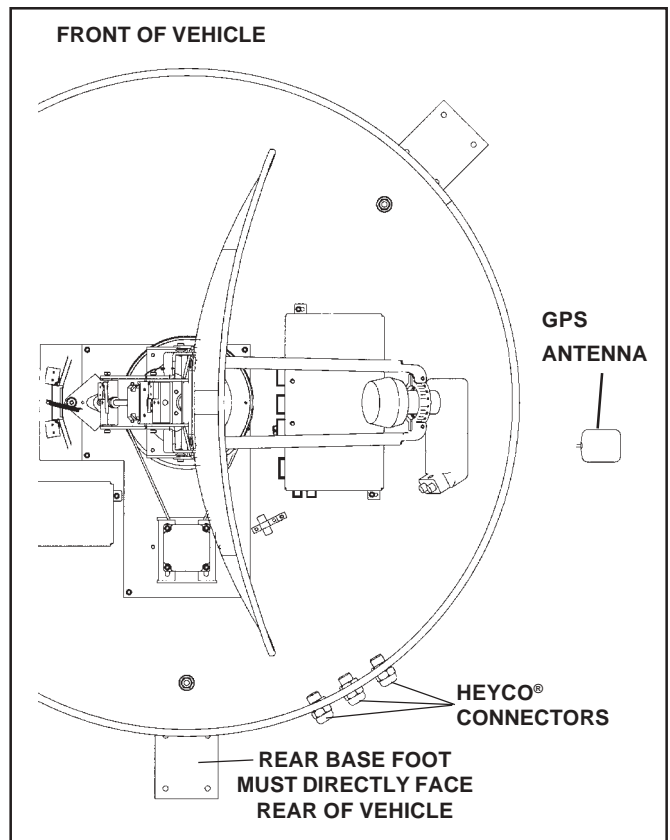

Cable entry installation —

1. Decide the best **location for the cables** to enter the vehicle, *and* the **location of the switch and receiver** (see “Installing the switch and receiver” below.) Drill a 1/2” hole in the roof, push wires inside. Make proper connections (**remember you must have filtered +12 VDC power source**).
2. Place cable-entry plate over hole and cables. Screw in place. Seal plate and screw holes with approved sealant (not included).

FIGURE 7

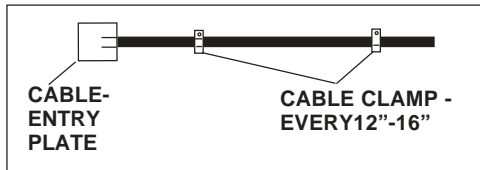

3. Depending on the length of the cable on the roof, you may need to use cable clamps or wire ties (not provided) between the unit and your cable-entry plate. Clamping the cable every 12”-16” should eliminate any unnecessary cable movement, Figure 7.

INSTALLATION

1. Decide the location of the power on/off switch. **Be sure the switch is turned off before you begin!** See diagram below.

Wall or panel mount: Drill 1-1/4” hole, pull wires through wall or panel.

Surface mount: Determine location and direction of box. Mount box feed wire into one of the box openings.

Select plate cover (brown or white provided) and snap the rocker switch into the switch plate. Be sure switch is off!

2. Connect +12 VDC power from vehicle, using red spade connector, to isolated spade on switch.
3. Connect red power wire from MV-0500 using red spade connector to center spade on switch.
4. Connect vehicle ground and black ground wire, using yellow spade connector, to silver spade on switch.

FIGURE 8

INSTALLING THE POWER SWITCH DIAGRAM

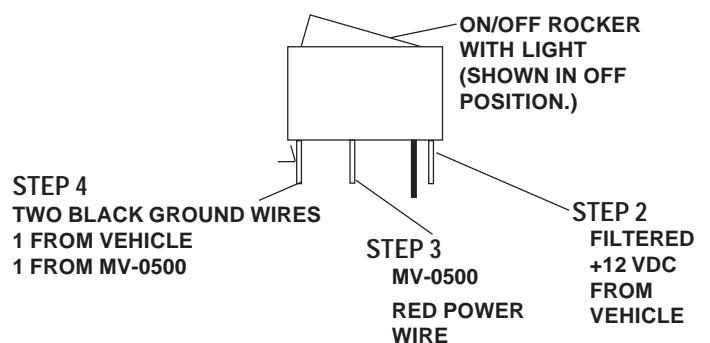

Installation • Wiring

Connecting the receiver —

Connecting one receiver

1. Connect the coax cable from the MV-0500 to the “SATELLITE IN” on the receiver.

WIRING ONE RECEIVER

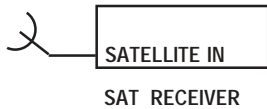

Connecting two receivers

1. Connect the coax cable coming from the MV-0500 to the “SATELLITE IN” input on the primary receiver. The primary receiver is the receiver used most often.
2. Run a second cable through the empty Heyco opening and connect to the ground block-type feed through and connect the other end of this cable to “Satellite IN” input on the second receiver.

WIRING TWO RECEIVERS

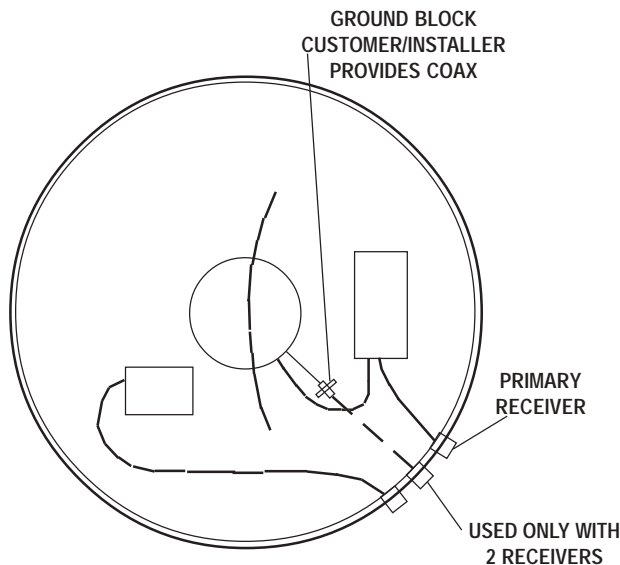
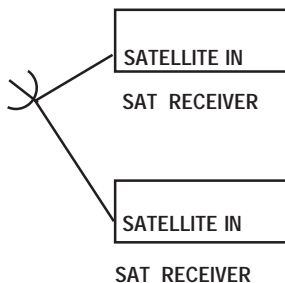

Initializing & replacing the dome after connecting the receiver(s) —

1. Be sure vehicle is in a location free of all obstructions and with a clear view of the satellite.
2. DO NOT MOVE VEHICLE during the first initialization. Power up unit, turn on receiver. FOR THE FIRST TIME ONLY, the unit may take up to 10 minutes to initially find the satellite signal. The GPS is also initializing at this time. After the GPS initializes, the unit will begin searching for the correct satellite.
3. **If the GPS does not initialize at this time**, turn off the unit. You may need to move the GPS antenna to a different location on your roof. After you move the GPS, DO NOT SECURE TO ROOF.
4. **TEST YOUR SYSTEM BEFORE SECURING THE GPS ANTENNA.** Make sure the TV/receiver have the correct satellite.
5. After the correct satellite has been found, secure GPS antenna by removing adhesive backing and securing to roof.
6. Install dome. **NOTE:** After Heyco connectors are tightened, **apply bead of silicone around the connector** where the exterior hex nut touches the base and **around the cables** where they enter the Heyco on the exterior of the unit. See drawing below. **If second receiver is not used**, apply silicone to seal center hole of third Heyco. See drawing below.

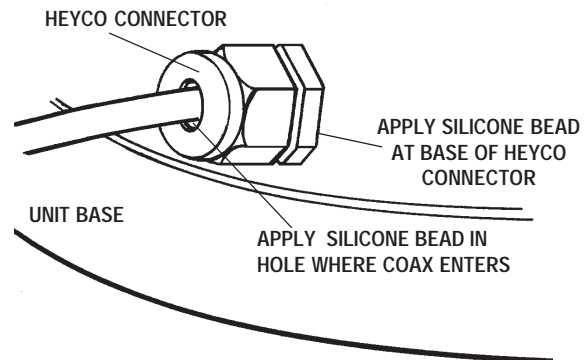

8. Before inserting screws on sides of dome, apply silicone to ENTIRE oval slot in gasket AND to screw threads, then insert screws and tighten. See drawing.

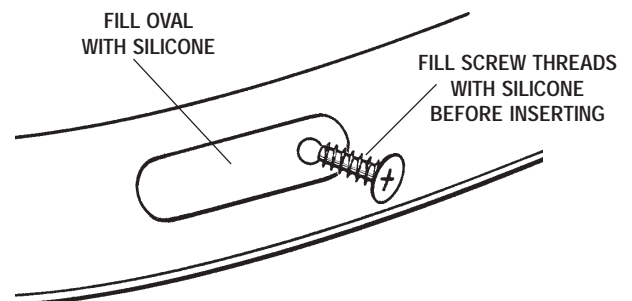

Your new MV-0500 features:

- GPS technology
- Fast signal acquisition times
- Easy “one-button” operation
- Ability to toggle between satellites using remote control, if subscribing to multi-satellite programming
- Low maintenance
- Compatible with continental U.S. digital satellite receivers
- Winegard warranty

To operate your system —

Vehicle must be parked.

1. Turn on receiver and television set. **This unit will not operate unless receiver is on.** Be sure your TV is turned to channel 3 or 4.
2. **Turn your +12VDC power switch to ON position.**
3. **Allow up to 3 minutes for signal location.** Satellite signal acquisition will occur with normal operating conditions.

NOTE: Acquisition time will be longer if the vehicle has traveled more than 600 miles without the unit in use. **If you have traveled this distance without using the unit, signal acquisition may take up to five minutes.**

4. **If you do not have a signal after three minutes,** be sure there are no obstacles preventing signal acquisition. (Trees, hill, buildings or other structures can block the signal.) Move to an open area so your system can “see” the satellite signal.

To toggle between satellites when subscribing to multi-satellite programming—

The MV-0500 will toggle between two different satellites. Both DIRECTV and DISH Network have programming on more than one satellite.

When a channel is selected on the remote control and it is not located on the satellite the unit is currently on, the system on the vehicle will automatically move to the new satellite.

DIRECTV programming

1. There is NO SETUP required for DIRECTV. When you request a channel located on a different satellite, the unit will automatically move to that satellite.

DISH Network programming

NOTE: This must be a DISH 500 system. These steps must be done each time the receiver loses 110 VAC power.

1. Let unit acquire the satellite signal on satellite 119.
2. After signal has been acquired, press the MENU key on the remote control or receiver.
3. Go into the SYSTEM SETUP menu.
4. Go into the INSTALLATION menu.
5. Go into the MULTI-DISH installation.
6. Scroll down to the CHECK SWITCH button and select.
7. The receiver will verify that you want to perform a “Check switch.” Select CHECK.
8. The receiver will begin checking your switch by toggling between transponders. When this is completed, a message stating “satellite reception is verified” will show. When it does, select OKAY. If this message does not appear, repeat steps 1 - 7.
9. Your system is now set up to toggle between satellites. It will automatically move to correct satellite when channel is selected.

Troubleshooting

IF YOU DO NOT HAVE A SIGNAL:

1. The signal may be blocked by trees, hills or structures. Pull into an area where no trees or buildings are in the line of sight from unit to the satellites.
2. **Check your +12 VDC power switch.** Make sure it is in the ON position.
3. **Check your connections.** The receiver must be connected to the power and coax connected from receiver to the satellite dish.
4. **Check your power supply.** The +12 VDC power supply must be hooked up. Check for +12 VDC on the roof at the connector.
5. Is the rear adjustable base bracket facing the rear of the vehicle? See Figure 1, page 4.
6. Loss of signal may also be caused by snow on roof of vehicle.

NOTE: The power rocker switch must be ON for

the next steps. Voltage must be +12 VDC, except at the LNBF, see Figure 9, page 11.

6. To check voltage at connections, see Figure 9 on page 11. FOLLOW THE NUMERICAL SEQUENCE ON THE DRAWING AND CHECK VOLTAGE AT:

- #1. Power Supply.
 - #2. LNBF voltage. Disconnect the coax cable from the LNBF. Check voltage from the middle wire to the shield. There should be +12 to +19 VDC. **If no voltage is present**, make sure receiver is on and check for +12 to +19 VDC at ends of gray coax cable (remove at box junction).
 - #3. 'Mini-cable' connection voltage at Control Box.
 - #4. Coax cable at Control Box going to Heyco connector.
7. Are the rotary dip switches in the correct position (101 or 119 or 092)?
 8. If the unit still does not have a signal, power off and power back on.

PROBLEM

Signal strength screen meter shows some signal strength, but constantly moves up and down, and is never locked on satellite.

Unit continues to move, but never finds any signal.

The unit continues to move and the signal strength screen shows that it is finding the satellites, but will never lock onto any satellite. Continues to search.

The unit moves around in circles, then points off the front of the coach.

SOLUTION

Check your power voltage. You may have dirty power. You must have a minimum of +12 VDC. Make sure receiver is on and connected properly. Check rotary dip switches for correct setting. (i.e. DISH network 119°, DIRECTV 101°, etc.).

Be sure the **switches** are set on the correct numbers — see **page 5, step 5.**

The **GPS** is not acquiring a signal.

FIGURE 9

FRONT OF VEHICLE

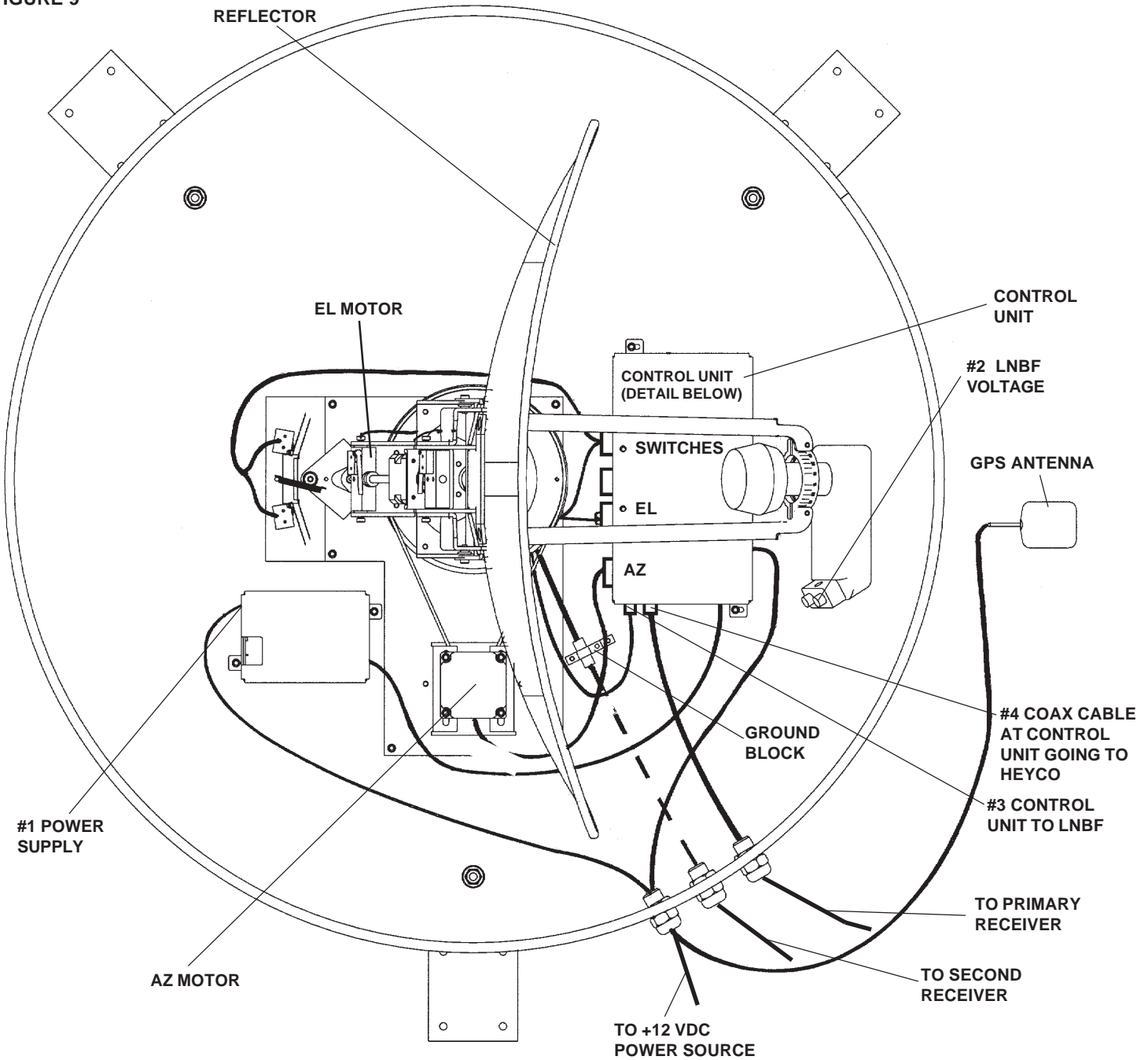

BACK OF VEHICLE

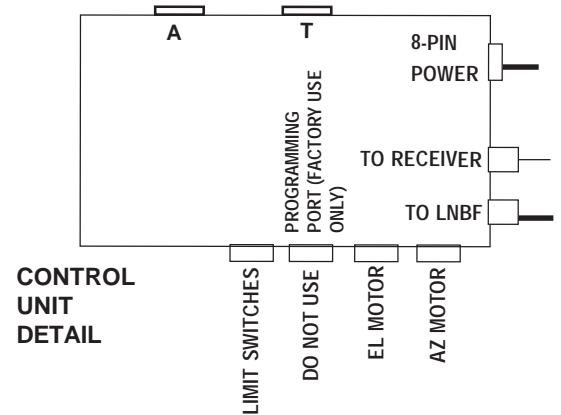

Specifications & Warranty

Features and specifications

- One button operation.
- GPS satellite signal acquisition.
- Depending on receiver type, you can access satellites 119°, 110° or 101°.
- No user input required.
- No data port required for any receiver.
- Elevation range 17° to 75°; azimuth +360°. (0 - 720°)
- 30' power cable and 30' coaxial cable included.
- Manufactured from sturdy ABS plastic, UV protected.
- Off-white color compatible with all vehicles.
- Compact size —
32" diameter, 15" height
Weight of unit - 43 lbs.
Shipping weight - 59 lbs.

TWO YEAR LIMITED WARRANTY

Winegard Company warrants this Winegard product (excluding receiver) against any defects in materials or workmanship within two (2) years from date of purchase. No warranty claim will be honored unless at the time the claim is made, you present proof of purchase to an authorized Winegard dealer (if unknown, please contact Winegard Company, 3000 Kirkwood Street, Burlington, Iowa 52601-2000, telephone 319-754-0600).

Winegard Company (at its option) will either repair or replace the defective product at no charge to you. This warranty covers parts, but does not cover any costs incurred in removal, shipping or reinstallation of the product. This limited warranty does not apply if the product is damaged, deteriorates, malfunctions or fails from: misuse, improper installation, abuse, neglect, accident, tampering, modification of the product as originally manufactured by Winegard, usage not in accordance with product instructions or acts of nature such as damage caused by wind, lightning, ice or corrosive environments such as salt spray and acid rain.

The Two Year Warranty is provided on the condition that the equipment is properly delivered with all handling and freight charges prepaid to your Winegard dealer for repair or return to our factory at the above address. Winegard dealers will arrange for the replacement or repair and return to you, without charge, the product which failed due to defective material or workmanship.

WINEGARD COMPANY WILL NOT ASSUME ANY LIABILITIES FOR ANY OTHER WARRANTIES, EXPRESS OR IMPLIED, MADE BY ANY OTHER PERSON.

ALL OTHER WARRANTIES WHETHER EXPRESS, IMPLIED OR STATUTORY INCLUDING WARRANTIES OF FITNESS FOR A PARTICULAR PURPOSE AND MERCHANTABILITY ARE LIMITED TO THE TWO YEAR PERIOD OF THIS WRITTEN WARRANTY.

The foregoing shall be the sole and exclusive remedy of any person whether in contract, tort or otherwise, and Winegard shall not be liable for incidental or consequential damage or commercial loss, or from any other loss or damage except as set forth above.

Some states do not allow limitations on how long an implied warranty lasts, or the exclusion of limitation of incidental or consequential damages, so the above limitations or exclusions may not apply to you.

This warranty gives you specific legal rights and you may also have other rights which vary from state to state.

